



上海山合海融商贸有限公司

Shanghai Shanhe & Hairong Commerce Co., Ltd.



HASEGAWA

日本 HASEGAWA 检电器、核相器产品

- 音响发光式检电器
- 无线检相器
- 手臂型高压活线接近警报器
- 安全帽使用型活电警报器
- 手表型活电接近警报器
- 便携式充电检电器
- 特高压检电器

www.shhairong.cn

山高水长，合则相宜

海纳百川，有融乃大

西班牙 LIFASA 电容器

台湾 SEW 仪器仪表

美国 salisbury 产品

美国 KUDOS 液压工具

法国 TAG6000 核相器

日本长谷川检电仪器

日本 YS 绝缘防护产品

Suparule 测高仪

带电作业用绝缘产品

张力放线施工设备

液压工具及压接机

压接机等液压工具

充电、手动液压切刀

高低压检电测试仪器

电线电缆处理工具

Q90 空调风量测试仪

高空防坠器、安全带

钢筋角钢铁板加工机

母线切断冲孔弯曲机

美翠 METREL 仪器

美国 Vanguard 仪器

美国 HOLADAY 仪器

TI27 红外热成像仪

国产安全防护产品

代理优势品牌列表



上海山合海融商贸有限公司是立足上海，面向全国，专业从事国产低压电器、安全防护、绝缘产品、仪器仪表、进口产品等产品的生产和销售。本公司自有品牌产品包括：SHPB 过电压保护器、SA2000-JS 过电压在线监测仪；销售商品定位在已有一定知名度的中高档品牌商品上，为客户提供

质优价廉的产品。本公司经营的主要产品包括西班牙 LIFASA 电容器、台湾标准电机 SEW 仪器仪表、美国 salisbury 安全防护产品、日本长谷川 HASEGAWA 检电器、美国 KUDOS 液压工具、美国 FLUKE 热成像仪、法国 TAG6000 核相器、进口专业机具和工具、道尔顿直饮净水器、绝缘靴、绝缘手套、放电棒、操作杆、绝缘毯、验电器信号发生器、验电器、接地线、电阻器、变阻器、断路器、接触器、电磁铁、制动器、熔断器、起动机、电容器、变压器、电压表、调压器、控制器、互感器、电流表、稳压器、继电器、隔离开关、测高仪、金钟穆勒、配电箱、转换开关、刀开关、组合开关、隔离开关、避雷器、按钮信号灯等。

电话(Tel): 021-5108 2245 13818244503

传真(Fax): 021-56889357

网址: <http://www.51082245.com>

E-mail: biz@shhairong.cn



在线客服



H
V
S
E
G
M
W
M

GENERAL CATALOGUE Vol.1

Voltage Detectors

Phase Testers

Auxiliary Devices for Voltage detection

Live-part display units

Voltage detector checkers

Grounding Devices

HASEGAWA ELECTRIC CO., LTD.



REGISTERED ORGANIZATION
No.0921-ISO 9001
No.E635-ISO 14001



JAB
CM002

This catalogue describes the features of our standard products and the outlines of specifications of those products. For the more detailed catalogs or technical materials etc. and any inquiries, please contact our dealers or our offices (See the back cover).

■ The outside dimensions and weights are shown in approximate values.

The outside dimensions are shown in the order of Width (W)×Height (H)×Depth (D), and, as a rule, the dimensions of protruding portions such as finger grips, rubber legs, handles, etc. are not included.

Table of contents

- Voltage detectors**
 - ◇ List of standard voltage detectors3
 - ◇ Audio-signaling and light emitting voltage detectors for low voltage4
 - ◇ Audio-signaling and light emitting voltage detectors for high and low voltage.....5
 - ◇ (AC and DC) Voltage detectors for high and special high voltage.....6
- Phase testers**
 - ◇ Low voltage phase-rotation meter.....7
 - ◇ Phase testers for high and special high voltage.....8
- Auxiliary devices for voltage detection.....9**
- Live-part display units10**
- Voltage detector checkers11·12**
- Pinwheel type voltage detectors12**
- Grounding hooks (Grounding and short-circuiting equipment)13~19**
- Instructions for use of voltage detectors (Operating principles)20~23**

Note: Specifications and prices are subject to change for improvement without prior notices.

Model	Product name	Rated voltage (V)	Detecting voltage (V)		Weight (g)	Market price
HTE-610	Low voltage detector - Audio-signaling and light emitting type	600	AC	50~600	22	
HT-620-ABC	Rechargeable Model Low voltage detector Set	600	AC	90~600	155	
HT-620-A	Rechargeable Model Low voltage detector	600	AC	90~600	30	
HT-620-B	Changing Cradle				35	
HT-620-C	AC. Adapter				90	
HT-680D	AC/DC low voltage detector - Audio-signaling and light emitting type (only for bare wires)	600	AC DC	50~600	27	
HT-680DS	// // (only for bare wires)	600	AC DC	50~600	27	
HT-680DB	// // (only for bare wires)	600	AC DC	50~600 12~600	27	
HT-680DBS	// // (only for bare wires)	600	AC DC	50~600 12~600	27	
HT-670	// //	600	AC DC	50~600	26	
HSF-7	AC high and low voltage detector - Audio-signaling and light emitting type	7,000	AC	80~7,000	150	
HSE-7G	// //	7,000	//	60~7,000	55	
HSS-25B	// Telescopic, audio-signaling and light emitting type	25,000	//	80~25,000	130	
HSE-7T1	// Audio-signaling and light emitting type	7,000	//	80~7,000	55	
HSG-6	// Telescopic, audio-signaling and light emitting type	7,000	//	80~7,000	85	
HSN-6A	High and low voltage detector for both AC and DC - Telescopic, Audio-signaling and light emitting type	7,000	AC DC	100~7,000 50~7,000	227	
HST-30	Special high voltage detector - Audio-signaling, light emitting and telescopic type	34,500	AC	3,000~34,500	340	
HST-70	// //	80,500	//	20,000~80,500	530	
HST-170	// //	195,500	//	60,000~195,500	600	
HST-250	// //	287,500	//	150,000~287,500	1030	
HST-1.5N	High voltage detector for both AC and DC - Audio-signaling and light emitting type	7,000	AC DC	600~7,000	340	
HST-20N	Special high voltage detector for both AC and DC - Audio-signaling and light emitting type	25,000	AC DC	3,000~25,000	610	
HST-W80JS	Voltage detector for AC trolley wire	80,500	AC	20,000~80,500	1010	
HS-1.5NR	High voltage detector for both AC and DC - Audio-signaling and light emitting type	6,600 7,000	AC DC	6,000~7,000 1,000~7,000	3150	
HS-1.5NJ	// //	6,600 7,000	AC DC	6,000~7,000 600~7,000	3140	
HS-500	AC special high voltage detector - Audio-signaling and light emitting type	550,000	AC	250,000~550,000	4730	
HS-90N	Special high voltage detector for both AC and DC - Audio-signaling and light emitting type	90,000	AC DC	6,000~90,000	1510	
WM22~275	High and special high voltage detector - Pinwheel type		AC	6,600~275,000	/	
PC-2	Low voltage phase rotation meter - Light and sound type phase tester	600	//	100~600	300	
PC-3	// //	400	//	200 · 400	250	
HPI-A6	High voltage phase tester - Optical fiber type	3,300 · 6,600	//	3,300 · (6,600)	600	
HPI-S6	// //	6,600	//	6,600	900	
HPI-S20	Special high voltage phase tester - Optical fiber type	33,000	AC	22,000~33,000	900	
HP-U6 · (U3)	High voltage phase tester - Wireless type (Radio)	6,600 · (3,300)	AC	6,600 · (3,300)	2500	
HP-S6 · (S3)	// //	6,600 · (3,300)	//	6,600 · (3,300)	1800	
HP-T6 · (T3)	// //	6,600 · (3,300)	//	6,600 · (3,300)	1400	
HP-U20	Special high voltage phase tester - Wireless type (Radio)	33,000	//	22,000~33,000	4400	
HP-S20	// //	33,000	//	22,000~33,000	1800	
HX _{6S}	High voltage hot-line proximity alarm unit	6,600	AC	6,600	$\frac{53}{59}$	
HXW-1	Wrist alarm	6,600	AC	6,600	28	
HXC-3K	Portable live-part detector		AC	3,300~77,000	83	
HHV-6T	Audio-signaling and light emitting type live-part display unit for high voltage	7,000	//	7,000	450	
HH-6A	Non-live-part display unit	6,900	//	3,000~7,000	580	
HSH-K6	High voltage cutout operating rod c/w a voltage detector	7,000	//	6,600又は7,000	390	
HLA-1	Voltage detector checker				430	
HLL-1	//				640	
HLL-6D	//				600	
CL-1-06	//				300	
HLA-2G	//				700	
HLA-N1	DC voltage detector checker				280	

Note: Specifications and prices are subject to change for improvement without prior notices. (The consumption tax is not included.)
The above product weights and dimensions are standard values.

■ For AC Low Voltage Only

Model **HTE-610** For low voltage (AC50V-600V)

volcheck[®]



- Overall length: 130mm
- Weight: 22g

Ultimate AC Low Voltage Model

1. Uses detecting tip with minimum sensitivity variance between bare cable and insulated cable.
2. Can detect voltage over insulation.
3. Incorporates new IC.
4. Comes in three colors.

Operating voltage range	AC50V-600V, 50/60Hz
Operation starting voltage (Voltage to ground)	Adjustable detection sensitivity Default setting: AC40V±10V (with detecting tip touching company standard insulated cable (600V-IV,2mm ²))
Operation status display	Light: intermittent red light emission verifiable at 8000Lx Sound: intermittent sound, 50dB and above at 30cm distance
Battery	Alkaline cell battery LR44 (1.5V)×2
Life of the battery	Continuous operation: about 10hrs, unused: about 1.5yrs (with new batteries)

* Without case

Model **HT-620-A** AC90V~600V

Purchase of three-piece assembly (HT-620-A, HT-620-B, HT-620-C) required initially.

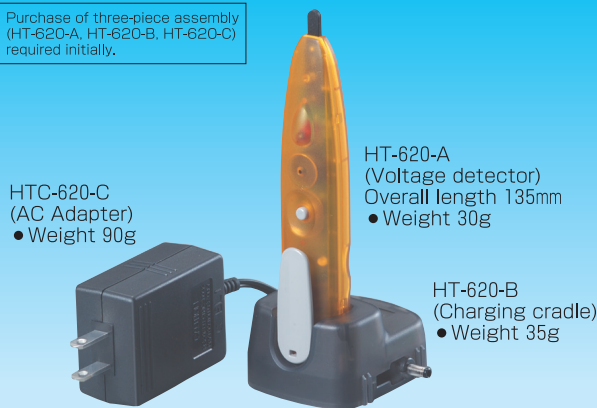

HTC-620-C (AC Adapter)
• Weight 90g

HT-620-A (Voltage detector)
Overall length 135mm
• Weight 30g

HT-620-B (Charging cradle)
• Weight 35g

Eco-friendly Rechargeable Model

1. Non-adjusting voltage detector.(Sensitivity adjustment not required. Easy voltage detection)
2. Compact size is suitable for portable use.
3. Uses conductive rubber on the tip to prevent shorting.
4. Can detect voltage over insulation.
5. Up to five charging cradles can be linked together.

■ Voltage Detector

Operating voltage range	AC90V-600V, 50/60Hz
Operation starting voltage (Voltage to ground)	Fixed operating sensitivity AC30V±10V with detecting tip touching insulated cable. (600V-IV)
Operation status display	Light: intermittent red light emission verifiable at 8000Lx. Sound: intermittent sound, 50dB and above at a distance of 30cm
Battery (Power source)	Rechargeable (Large capacity capacitor), with internal capacitor life of 5 years and above Charging time: about 3 minutes (time from discharged state to fully charged)

■ Charger

Model	HT-620-B (charging cradle)/HT-620-C (AC adapter)
Input	AC100V, 50/60Hz 12VA (AC adapter)
Output	5V-1A (max) (AC adapter)
Charging method	Low voltage charge

* Without case

■ For AC and DC low voltage (special use for bare wires)

Model **HT-680D** for low voltage (AC/DC 50-600V)

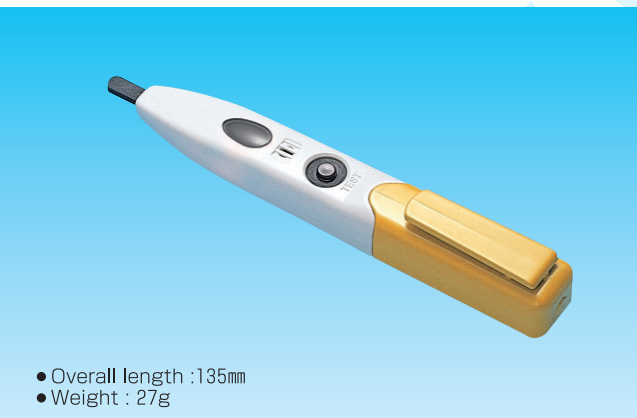

- Overall length :135mm
- Weight : 27g

Low voltage AC/DC type

1. Ideally suited for voltage detection during communication/control related work.
2. A conductive rubber material is used on the detection tip.
3. High sensitivity for 50V even for both AC and DC
4. The sound and light helps checking without fail.

Frequency	50/60Hz
Operation starting voltage	AC30±10V, DC35±10V
Operating status indication	Light emission: Red light emission continuously. The light is visible in the brightness of 8,000 lx. Sound: Continuous sound of 50 dB or louder in a position 10 cm away from the unit.
Battery	Alkaline cell battery LR44 (1.5V)×2
Life of the battery	About one year in normal use

Series model	Detection tip	Detecting voltage
HT-680D	Conductive rubber	AC50~600V, DC50~600V
HT-680DS	Metal	AC50~600V, DC50~600V
HT-680DB	Conductive rubber	AC50~600V, DC12~600V
HT-680DBS	Metal	AC50~600V, DC12~600V

* Without case

Model **HT-670** for low voltage (AC/DC50-600V)

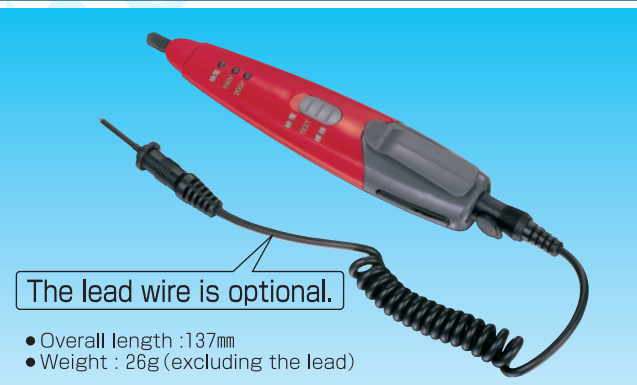

The lead wire is optional.

- Overall length :137mm
- Weight : 26g (excluding the lead)

New form made by the first-class designers

Multi-functional type possessed by professional electricians

1. Introduced voltage distinction is possible.
2. The sensitivity level may be changed depending on applications.

Frequency	50/60Hz	
Operation starting voltage (Voltage to ground)	Switch:Coating	AC40V for insulated wires(IV,2mm ²)(Intermittent operation) AC30V±15V or DC30V±15V for bare wires(Continuous operation)
	Switch:Bare wire	(When connected with lead wires) 100V LED comes on: AC, DC 30V±20V (Continuous operation) 200V LED comes on: AC, DC 140V±30V (Continuous operation)
Battery	Alkaline cell battery LR44 (1.5V)×2	
Life of the battery	About one year in normal use	

* Without case

Model HSF-7 AC80V~7000V



- Overall length : 260mm
- Weight : 150g

Popular model for the high voltage of 6kV

1. Possible to distinguish between the high and the low voltage by intermittent and/or continuous sound and light.
2. Easily operable having no selector switch.
3. Safe with the dual structure for pressure resistance and water proof.

Rated operation starting voltage	Low voltage	Exposed live part : 80V(contact with the live part)
	High voltage	Exposed live part : 400V(contact with the live part)
	Insulated wire	(ϕ 0.5mm OE wire) 3,000V
Rated non-operating distance	Intermittent	(Voltage to ground 4kV) 50cm
	Continuous	(Voltage to ground 4kV) 3cm
Service temperature range	-10°C~+50°C	
Battery	AAA battery (1.5V) R03×2	

Accessory: Leather case

Compliant with the safety guidelines for portable-type voltage detectors used for high-voltage electric wiring lines (RIS-TR-85-2 of the industrial safety research institute, Ministry of Labor)

AC High/Low Voltage Detectors

Model HSE-7G AC60V~7000V

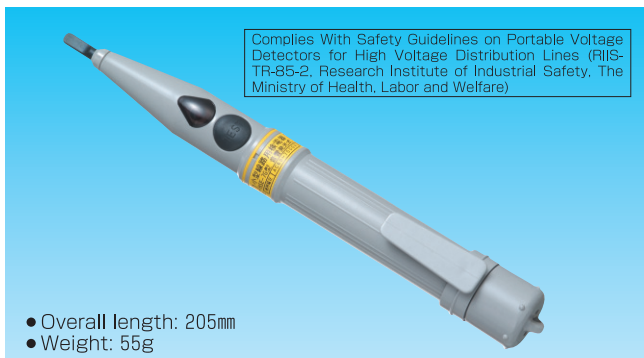

Complies With Safety Guidelines on Portable Voltage Detectors for High Voltage Distribution Lines (RIS-TR-85-2, Research Institute of Industrial Safety, The Ministry of Health, Labor and Welfare)

- Overall length: 205mm
- Weight: 55g

Ultimate Compact Model for 6kV High Voltage

1. Perfect for voltage detection in communication work.
2. Super-compact and lightweight, with pressure-resistant dual construction.
3. Replaceable conductive rubber detecting tip.

Rated operation starting voltage	Low voltage	Exposed live part : 60V (in contact with live part)
	High voltage	Exposed live part : 400V (in contact with live part)
	Insulated wire	(5mm ϕ OE wire) 3,000V
Rated non-detecting distance	Intermittent	(4kV voltage to ground) 50cm
	Continuous	(4kV voltage to ground) 5cm
Operating temperature range	-10°C~+40°C	
Battery	Alkaline cell battery LR44 (1.5V)×2 Battery life 3hrs continuous operation, 2yrs unused	

*Accessory: storage case

Model HSE-7T1 AC80V~7000V

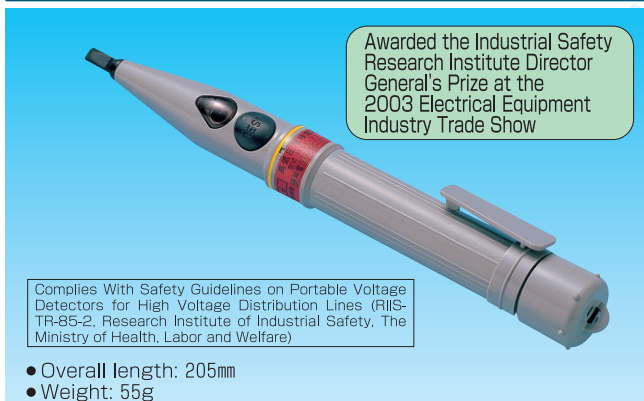

Awarded the Industrial Safety Research Institute Director General's Prize at the 2003 Electrical Equipment Industry Trade Show

Complies With Safety Guidelines on Portable Voltage Detectors for High Voltage Distribution Lines (RIS-TR-85-2, Research Institute of Industrial Safety, The Ministry of Health, Labor and Welfare)

- Overall length: 205mm
- Weight: 55g

Compact and Lightweight, Convenient Portability

1. Compact size fits in workwear breast pocket.
2. Provided with clip for carrying in pocket.
3. Replaceable conductive rubber detecting tip.

Rated operation starting voltage (Voltage to ground)	(Voltage detection through contact starts at or below following voltages)	
	Low voltage (intermittent sound/light indication)	Exposed live part : 80V
Rated non-detecting distance (Voltage to ground 4kV)	High voltage (continuous sound/light indication)	Exposed live part : 400V
	Insulated wire (5mm ϕ OE wire) 3,000V	
Operating temperature range	(Minimum non-detecting distance to wire (150mm ² OC))	
	Intermittent sound/light indication (for low voltage):	50cm
Battery	Continuous sound/light indication (for high voltage):	5cm
	-10°C~+40°C	
Alkaline cell battery LR44 (1.5V)×2 Battery life 3hrs continuous operation, 2yrs unused		

*Without case

Model HSS-25B AC80V~25000V Telescopic type

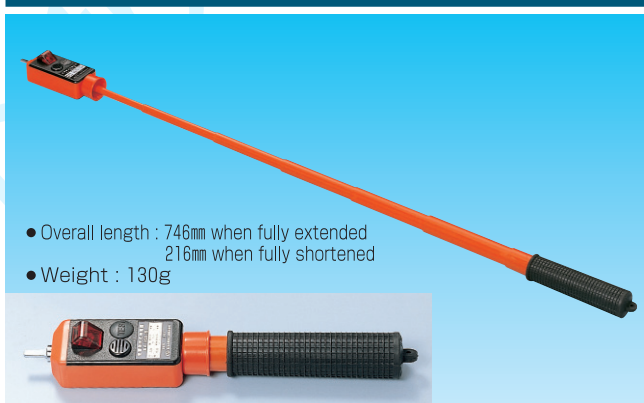

- Overall length : 746mm when fully extended
216mm when fully shortened
- Weight : 130g

1. Ideally suited for maintenance service of high-pressure cubicles.
2. Shorten the unit for low voltage detection, and extend the unit for high voltage detection.
3. The detecting part is water-proof structured.

Rated operating voltage (Minimum response voltage to ground)	For high voltage (Detect holding the grip)	
	Bare wire (ϕ 3mm) :	AC250V±50V
Service temperature range	OC wire (5mm) :	AC1000V±200V
	For low voltage (Detect holding nameplate portion)	
Operating status indication	Bare wire :	AC80V or below
	-10°C~+50°C	
Battery	Alkaline cell battery LR44 (1.5V)×2	
Life of the battery	About one year in normal use	

Accessory: Leather case

Model HSG-6 AC80V~7000V

- Overall length fully extended: 800mm retracted: 200mm
- Weight: 85g



Lightweight, Compact, Telescopic Model

1. Safe conductive rubber used on detecting tip.
2. Super-compact and lightweight at 85g.
3. Replaceable conductive rubber on detecting tip is economical.

Rated operation starting voltage (at Voltage to ground)	(Voltage detection starts at or below following voltages in retracted state) High voltage (continuous sound) Exposed live part: 400V Insulated wire (5mmφ OE wire) 3,400V (extended and retracted) Low voltage (intermittent sound) Exposed live part: 80V
Operation status display	Light emission: verifiable under 8,000Lx light Sound emission: 50dB or above at 1m distance
Operating temperature range	-10°C~+40°C
Battery	Alkaline cell battery LR44 (1.5V)×2 Battery life 3hrs continuous operation, 2yrs unused
Life of the battery	Continuous operation: about 8hrs, unused: 2yrs

*Storage case sold separately

Model HSN-6A

- Overall length : 810mm when fully extended 278mm when fully shortened
- Weight : 290g



High-performance detector usable for a wide range of applications

1. Lightweight and easy-to-use telescopic type being convenient to carry
2. High voltage detection ranging from 3kV to 7kV is possible in both extended and shortened conditions.
3. May be used for voltage detection of a low-voltage circuit if holding the name plate of the detecting part.

Service voltage range	Without a ground wire	AC 3kV-7kV (Voltage detection by holding the grip) AC 100V-600V (Voltage detection by touching the name plate with the hand)
	With a ground wire	AC 100V~7kV and DC 50V~7kV (Withstand voltage test: possible up to DC 21kV)
Operating status indication	Light: Red light for AC, Yellowish red light for DC, The light is visible in the brightness of 8,000 lx. Sound: Intermittent sound of 60 dB or louder in a position 1 m away from the unit.	
Service temperature range	-10°C~+50°C	
Battery (Built-in)	Alkaline cell battery LR44 (1.5V)×2	
Accessories	Plug, 3-meter ground wire c/w a clip×1, Leather case×1	

Model HST Series



Serialized product models ranging from the special-high voltage to the high voltage

1. Telescopic type and lightweight
2. Designed to cut battery drain
3. The sound and light helps checking.
4. The detecting part is variable for easy viewing.
(Models HST-70, HST-170, HST-250)

※ Models HST-1.5N and HST-W80JS have a hook-type tip fitting.

Frequency	50/60Hz
Service temperature range	-10°C~+50°C
Operating status indication	Intermittent light and sound
Battery	Alkaline cell battery LR44(1.5V)×2
Life of the battery	About one year in normal use

Model	Service voltage range	When extended	When shortened	Weight(g)
HST-30	AC 3~ 34.5kV	1382mm	846mm	340
HST-70	// 20~ 80.5	2260	1325	530
HST-170	// 60~195.5	3145	1290	600
HST-250	// 150~287.5	5055	1295	1030
HST-W80JS	// 20~ 80.5	5090	1320	1010
HST-1.5N	AC·DC 0.6~7	415(not extendable)		340
HST-20N	AC·DC 3~2.5	940(not extendable)		610

Accessory : Bag for housing

Model HS Series



For detection of the super-high voltage and the special-high voltage

1. The light can be seen even outdoors in the daytime, and the sound can be heard even in a high-noise environment.
2. Excellent and robust structure
3. A unit with custom-designed sensitivity can be manufactured.

Model	HS-1.5NR	HS-1.5NJ	HS-500	HS-90N
Service voltage range (V)	AC6,000~7,000		AC250,000~550,000	AC6,000~90,000 DC6,000~90,000
	DC1,000~7,000			
Size (mm)	4,500	4,500	7,085	1,585
Weight (g)	3,150	3,140	4,730	1,510
Battery	9V Battery 6F22 (S-006P)			

Accessory : Bag for housing

- ※ The DC voltage detectors are provided with one 7-meter ground wire.
- ※ All models are provided with a bag for carriage.
- ※ The insulated operating rods of HS-20N and HS-90N models are not telescopic types.

Model PC-2



- Outer dimensions : 65×91×25mm
- Weight : 300g

Phase-rotation meter telling the result by sound and lighting

1. The result can be double-checked by the eyes and ears.
2. Open-phase judgment is available for 200V and over.
3. Phase rotation can be checked in the wide range from 100V to 600V.
4. The unit seldom fails, so semi-permanently usable.
5. Compact and lightweight being convenient for handling.

■ Classification of phase rotations

	Positive phase	Negative phase	Open phase
Lamp indication	Green	Red	Green/Red
Warning sound	Nil	Intermittent sound	Continuous sound

■ Specifications

Service voltage	100V (Continuous) ~600V (within 30 seconds)
Power supply	No separate power supply is required.

Manufactured by OTOWA Electric Co., Ltd.

Model PC-3



- Outer dimensions : 140×60×28mm
- Weight : 250g

Phase rotation can be checked on the insulating coating.

1. Even the insulated wire can be checked.
2. The result can be double-checked by the eyes and ears.
3. The large-size clips enable checking of various size electric wires ranging from 2mm² to 100mm².
4. Compact and lightweight being convenient for handling.

■ Classification of phase rotations

	Positive phase	Negative phase
Led blinking light color	Green	Red
Buzzer sound	Nil	Intermittent sound

■ Specifications

Service voltage	3 phase AC200V/400V
Frequency	50/60Hz
Battery	6F22(S-006P) 9V
Electric wire size	2mm ² ~100mm ²

Manufactured by OTOWA Electric Co., Ltd.

Model HPI-A6·HPI-S6



Awarded the director general prize from Industrial Safety Research Institute in Electric Equipment Industry Exhibition in 1990

Insulating with an optical fiber wire between the two detecting parts

- Each one of the pair may be used for voltage detection, and the pair may be used for checking phase rotation and sequence.
- Measurement on the covered wire**
Similar to voltage detectors, this unit has the high-level input impedance making it possible to measure on the voltage detection terminal and the covered wire.
- Same display method as that of conventional one**
The operating procedure and the display method are same as those of the phase tester for overhead wires. This unit also gives out sound (buzzer) and light (LED) to tell the in-phase, different phases and phase sequence.
- Safely used even for high-voltage bare wires**
The unit has excellent electric features and sufficient dielectric strength (200kV/min), and durable against high-temperature, moisture and shock.
- Compact, lightweight and easy to use.**
Consisting of the transmission and reception parts as well as the optical fiber wire connecting those two parts, and the unit is housed in a plastic case of $\phi 34\text{mm} \times 273\text{mm}$ long. (HPI-A6 model)
- Test button and battery drain cutting**
The unit is provided with a test button to pre-check conditions of the internal circuit and the battery. The circuit enables battery drain cutting when the unit is not used.

Model	HPI-A6	HPI-S6	HPI-S20
Structure	Underground line cubicle	For overhead wires	
Service voltage	3.3kV~6.6kV	6.6kV	22-22kV
Housing	Attache case	Bag	
Frequency	50Hz/60Hz		
Insulation resistance	2,000MQ or over		
Dielectric strength	20kV per minute		75kV per minute
Overall length	When extended 928mm	1,985mm	1,985mm
	When shortened 398mm	1,200mm	1,200mm

Phase test	Detect if the phase is in-phase or in 120°different phase.	
Phase sequence check	Detect if the phase is 120°leading or lagging.	
Representation	Light	The light is visible in the brightness of 8,000 lx.
	Sound	50dB or louder in a position 1 m away from the unit (Intermittent sound)
Service temperature	-10°C~+40°C	
Distance for phase test	3 meters between the transmission and receiving positions×2 wires (30meters for a special order)	
Battery	N cell battery (1.5V) R1×2each	

Model HP Wireless phase detection method

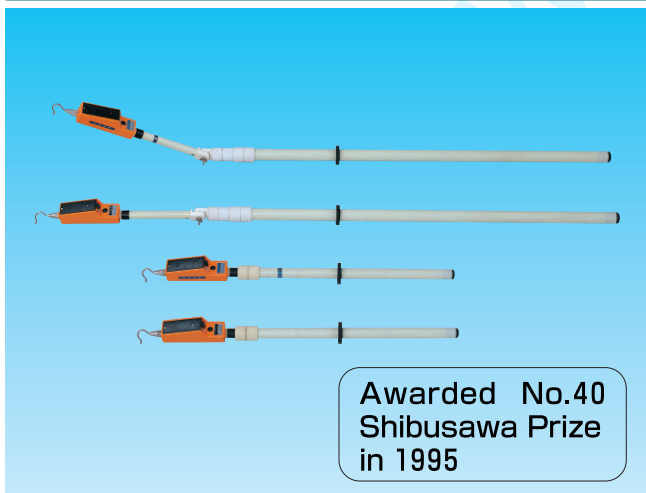

Awarded No.40 Shibusawa Prize in 1995

Easy-to-use wireless type

- Perfectly insulated structure**
This unit can be used for both bare wires and insulated wires, having a safe structure as the detecting part is completely insulated.
- Wireless type phase comparison**
Safe and easy-to-operate. The phase test is performed by a phase comparison method by means of an electronic circuit without connection wires as the two detecting parts may be linked by radio waves.
- Test button**
The test button is to securely check functions of voltage detection, phase test, transmission and reception of radio waves, and batteries.
- Waterproof structure**
The detecting part has a totally enclosed waterproof structure.
- Having no selector switch**
This unit does not have any selector switch, so there is no fear of an operating error. The battery power supply is designed for battery drain cutting, as the power turns ON only when the unit is operated.

Model	HP-U20	HP-U70	HP-S20	HP-S70	HP-U6	HP-S6	HP-T6	HP-U3	HP-S3	HP-T3	
Service voltage	for both 22kV&33kV	for both 66kV&77kV	for both 22kV&33kV	for both 66kV&77kV	for 6.6kV			for 3.3kV			
Overall length	When extended	3470mm	3470mm	1220mm	3245mm	1480mm	1220mm	550mm	1480mm	1220mm	550mm
	When shortened	1640mm	1640mm	850mm	1415mm	1090mm	850mm	—	1090mm	850mm	—
Weight	2200g×2	2400g×2	900g×2	2200g×2	1250g×2	900g×2	700g×2	1250g×2	900g×2	700g×2	
Dielectric strength	Between the hook fitting and the universal joint, 50kV, for 5 minutes Insulating rod (excluding the antenna) 75kV/30cm, 5 minutes				Representation	Light	The light is visible in the brightness of 8,000 lx.				
Phase test function	Distinguish between the in-phase and the 120°different phase.					Sound	50 dB or louder in a position 3 m away from the unit				
Distance for phase test	Distance between the transmission and reception parts Max. 5 m				Service temperature range	-10°C~+50°C					
					Structure of the detecting part	No water permeates in the inside		Battery	6F22 Battery(9V)×1		

■ High voltage hot-line proximity alarm unit

Model **HX-6** for 6.6kV

Upper-arm fitting type



- 52×40×16mm
- Weight : 53g

Awarded the president prize from Tokyo Electric Power Co., Inc. in Electric Equipment Industry Exhibition in 1993

Essential unit for high-voltage proximity work

1. Gives an alarm in the proximity of a high-voltage charge part
2. Ideally suited for the safety of electric work
3. Waterproof structure

Distance and the voltage for an alarm	6.6kV (Voltage to ground) -80cm(in the standard condition)
Sound volume	65dB or louder (in a position 1 meter away from the unit)
Battery	JIS CR2025 or CR2032 lithium battery
Life of the battery	About 50 hours in total if continuously operated About 2 years if not operated at all
Service temperature range	-5°C~+45°C
Frequency	Either 50Hz or 60Hz specified by users

Model **HX-6S**

for 6.6kV
Helmet fitting type



- Weight : 59g

■ Wristwatch type hot-line proximity alarm unit

Model **WRIST ALARM HXW-1**

Wristwatch type



- 40×37×13mm
- Weight : 28g

For prevention of electric shock accidents due to illusions, mistakes, etc.

1. Gives out an alarm by an electronic buzzer sound in the proximity of live parts.
2. Ideally suited for prevention of human errors as the unit is always set under the stand-by state for actuation having no switch of the battery.
3. The unit is totally enclosed preventing faults due to dust or dirt.

Distance and the voltage for an alarm	6.6kV (Voltage to ground) -60cm(in the standard condition)
Sound volume	65dB or louder (in a position 60cm away from the unit)
Battery	JIS CR1620 lithium battery ×1
Service temperature range	-5°C~+45°C
Frequency	Both 50Hz and 60Hz

■ Portable live-part detector

Model **HXC-3K**



- Overall length : 155mm
- Weight : 35g

Auxiliary device for voltage detection usable for a wide range of applications

Service voltage range	3.3kV~77kV (Non-contact for 11kV and over)
Service temperature range	-20°C~+40°C
Structure	Waterproof structure (No water permeates into the inside.)
Frequency	50Hz or 60Hz specified by users
Battery	Alkaline cell battery LR44(1.5V)×2
Dielectric strength	Between the detecting part tip and the grip AC20kV for one minute (Leakage current : 1mA or less)
Detecting performance	Voltage for actuation: 400V±20% Distance for detection: 3cm at 3.3kV, 10cm at 6.6kV
Representation of operating conditions	Light: The light is visible at a position 50cm away from the unit in the brightness of 8,000 lx. Sound: 50dB or louder at a position 1 m away from the unit

■ Voltage, distance for separation, and distance for detection

Voltage (kV)	3.3	6.6	11	22	33	77
Distance for separation	—	—	15	25	35	76
Distance for detection	5	10	33	90	120	230

■ Audio-signaling and light emitting type live-part display unit for high voltage

Model **HHV-6T**

Gives out an alarm against the danger of live parts by means of the sound and voice "Beep, beep, it's under charging" as well as light emission and diode blinking which can be seen from all directions.

1. Compact and lightweight being convenient to carry.
2. Clearly gives out an alarm against the charging condition by means of the sound and voice.
3. Indicates an alarm with revolving and blinking light.

- Overall length : 441mm
- Weight : 450g

Model	HHV-6T	Representation of conditions	Light: The light is visible in the brightness of 8,000 lx. Sound: 50dB or louder at a position 1 m away from the unit
Max. service voltage	AC 7,000V for both 50/60Hz	Service temperature range	-10°C~+40°C
Insulation resistance	Between the detection metal fitting and the grip, 100MΩ or over	Structure	Waterproof structure (No water permeates into the inside.)
Dielectric strength	- ditto - , AC15kV for one minute	Battery	Size C battery(1.5V)R14×2
Leakage current	At the time of a dielectric strength test, 500μA or less		

■ Audio-signaling and light emitting type non-live-part display unit

Model **HH-6A**

Non-live-part display unit used being hung on the live-part of AC high voltage which is easy-to-check the condition by means of bright light blinking and intermittent sound

1. Compact and lightweight being convenient to carry.
2. Represents the condition by means of intermittent sound and blinking light

- Overall length : about 500mm
- Weight : 580g

Model	HH-6A	Leakage current	At the time of a dielectric strength test, 500μA or less
Service voltage	AC3kV~7.2kV	Representation of conditions	Light : The light is visible in the brightness of 8,000 lx. The unit emits light under a condition of non-live-part. Sound : 50dB or louder at a position 2 m away from the unit. The unit makes a sound under a condition of non-live-part.
Operation starting voltage	AC800V±20% (with φ5mm OC wire) (Represents the condition of non-live-part under the voltage to ground of AC800V or lower)	Service temperature range	-10°C~+40°C
Insulation resistance	Between the detection metal fitting and the grip,100MΩ or over	Structure	Waterproof structure (No water permeates into the inside.)
Dielectric strength	- ditto - , AC20kV for one minute	Battery	AAA battery (1.5V) R03x2

■ High voltage cutout operating rod c/w a voltage detector

Model **HSH-K6**

Increases safety and efficiency in operation.

1. High voltage cutout switching and voltage detection can be done simultaneously.
2. High voltage detection range is between 1,600V and 7,000V.

- Overall length 470mm
- Weight : 390g

Model	HSH-K6	Representation of conditions	Light: The light is visible in the brightness of 8,000 lx. Sound: 50dB or louder at a position 2m away from the unit.
Service voltage	AC 6.6kV	Service temperature range	-10°C~+40°C
Operation starting voltage (Voltage to ground)	1,300V±20% (Continuous sound and light)(for insulated wires)	Structure	Waterproof structure (No water permeates into the inside.)
Insulation resistance	Between the detection metal fitting and the grip,100MΩ or over	Tensile strength	200kg. for one minute
Dielectric strength	- ditto - , for one minute	Shock resistance	Falling down once to the concrete surface from the height of 700mm (under horizontal condition)
Leakage current	At the time of a dielectric strength test, 1mA or less	Battery	9V battery 6F22(S-006P) x1

Battery built-in method **Handy type**

Model HLA-1

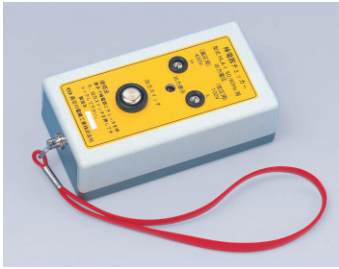

1. Easily usable at the work site.
2. Possible to check both of high and low voltage detectors.
3. Compact and lightweight being convenient to carry.

● 65×120×40mm ● Weight : 430g

Model	HLA-1	Service voltage range	-10°C~+50°C
Output voltage	H terminal...AC400V L terminal...AC100V	Built-in battery	6F22(9V battery) x1 Life of the battery... Total life time: about 2 hours
Output frequency	55Hz (+45Hz-10Hz)		
Load impedance	H terminal...5MQor over L terminal...500KQor over		

Model HLA-2G



Ideally suited for checking voltage detectors used for the communication equipment.

● 80×150×50mm ● Weight : 700g

Model	HLA-2G	Built-in battery	6F22(9V battery) x2 Life of the battery... Total life time: about 2 hours
Output voltage	H terminal...AC1,200V L terminal...AC70V	Service voltage range	0°C~+50°C
Output frequency	55Hz +10%	Voltage detector models for checking	Model HSC-7N, Model HSC-7G (Small-size voltage detectors for electric lines)
Load impedance	H terminal...5MQor over L terminal...500KQor over		

Model HLA-N1

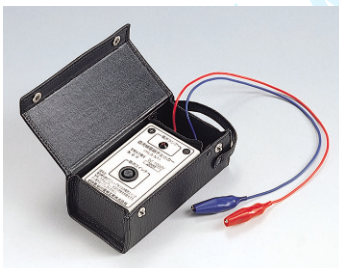

Special use for DC high voltage detectors
(Ideally suited for our models HS-1.5NR, HS-1.5NJ)

● 72×114×45mm ● Weight : 280g

Model	HLA-N1	Short-circuit current	0.5mA
Output voltage	DC1,000V	Built-in battery	R03(AAA battery 1.5V)x4
Load resistance	50MQ or over	Service temperature range	-10°C~+50°C

AC 100V power supply method **Wall mounting type**

Model HLL-6D



This unit can be used for checking both of AC low-voltage detectors and DC low voltage detectors.

● 110×140×46mm ● Weight : 600g

Model	HLL-6D
Input voltage	AC100V
Dielectric strength	2.0kV for one minute (between the input and the earth)
Short-circuit current	1mA or less
Output voltage	AC50V(±10%) DC+50V~+60V DC-50V~-60V

Model HLL-1



This unit can be used for checking both high and low voltage conductors. As being provided with two output terminals of AC100V and AC400V, this unit may check a variety of detectors for low voltage, high voltage, and high/low voltage.

● 110×140×46mm ● Weight : 640g

Model	HLL-1
Input voltage	AC100V
Output voltage	"For low voltage" AC100V(±10%) "For high voltage" AC400V(±10%)
Dielectric strength	2kV for one minute (between the input and the earth)
Short-circuit current	1 mA or less

Piezoelectric method **Handy type**

Model CL-1-06

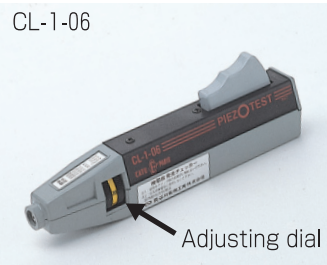

1. Compact, lightweight and pocket type
2. Checker for voltage detectors and phase testers

Product made under a tie-up between CATU, France and Hasegawa Electric Co., Ltd., Japan

Model	Specification	Size(mm)	Weight(g)	Accessory
CL-1-06	c/w Dial for adjustment (10-30) 10. Output voltage of about 3,500V 20. Output voltage of about 7,000V 30. Output voltage of about 11,500V	190x65x32	300	Lead wire for connection

c/w Bag for housing

Voltage detector models	Voltage detector checkers							
	HLA-1	HLA-2G	HLA-N1	HLL-1	HLL-6D	CL-1-06		
						10	20	30
HTE-610	○	○		○	○			
HT-620-A				○				
HT-680D	△	△		△	◎			
HT-670	△	△		△	○			
HSF-7	◎	○		◎		○	○	
HSE-7G	◎	○		◎		○	○	
HSS-25B	○	○		○		○	○	
HSE-7T1	◎	○		◎		○	○	
HSG-6	◎	○		◎		○	○	
HSN-6A		△	□	△	○	△	△	
HST-1.5N		△	□			△	△	
HST-20N						△	△	
HS-1.5NR		△	□			△	△	
HS-1.5NJ		△	□			△	△	
HST-30		○				○	○	
HST-70							○	
HST-170								◎
HST-250								◎
HST-W80JS								◎
HS-90N						△	△	
HS-500								◎
HS-500C						○		
WM22~275						◎	◎	◎
HP-U6 (U3)		○				○		
HP-S6 (S3)		○				○		
HP-T6 (T3)		○				○		
HP-U20 (S20)		○					○	
HP-U70 (S70)								◎
HPI-S6 (A6)		○				○	○	
HPI-S20							○	

For any inquiries, please contact us.

◎ means "most suitable". (Checkable depending on the voltage range and AC/DC).
 ○ means "checkable".
 △ means "available for AC, but not available for DC".
 □ means "available for DC, but not available for AC".
 Blank (no symbol) means "not checkable".

●Pinwheel type voltage detector Model WM (special use for AC)



This model is unique in respect that it detects voltage changing invisible electricity into a form of object movement, and is ideally suited for high voltage detection and indication. This model is insensitive to sunlight, or vibration from the transformer. In addition, it is possible to check if an electric line is dead or live at the same time by many people even if they are 10 meters away from the line.

Even if in a place where no power supply is located, the conditions of voltage detectors can be checked with this unit by means of a friction test. The pinwheel has a simplified structure and is sturdy, so it is tough against vibration and shock. (Passed a test of the industrial test institute in Tokyo)

Type	Service voltage	Application	Handle length (when extended)	Standard price (¥)	Tip metal fitting
No.22	AC6.6 ~ 22kV	General	1.3m	52,500	Straight
No.33	AC6.6 ~ 33kV	General	1.9m	55,500	
No.77 A	AC11 ~ 77kV	Maintenance	1.9m	55,500	
No.77 B	AC11 ~ 77kV	Power station and substation	2.3m	57,000	
No.154A	AC11~154kV	Maintenance	2.8m	67,500	
No.77 C	AC11 ~ 77kV	Power station and substation	3.4m	67,500	Spring
No.154B	AC11~154kV	Power station and substation	3.7m	72,000	
No.275	AC33~275kV	General	4.5m	101,200	

Grounding hooks

● Please specify the following items when ordering a grounding hook.

1. Type of the tip metal fitting
2. Type of the insulating rod (Joint and extension type, Telescopic type)
3. Length and diameter of the insulating rod
4. Cross-section area and length of the grounding wire
5. Type of the grounding metal fitting
6. Service voltage

Note

- One set for a three-phase is standard.
- A bag for housing is optional.
- As the product will be custom-made, please note the product may not be returnable to us after once ordered.

■ Jointing of operating rods (The standard rods of 3-meter or shorter are made as one-piece rods.)

Figures in the parentheses are the outer diameters of rods.

Operating rod length	38mm ² or smaller grounding wires are used.		60mm ² or larger grounding wires are used.
		Strong type head metal fittings are used.	
3.5m (2-piece joint)	1.5m (31φ) + 2.0m (34φ)	1.5m (31φ) + 2.0m (34φ)	1.5m (31φ) + 2.0m (34φ)
4.0m (2-piece joint)	2.0m (31φ) + 2.0m (34φ)	2.0m (31φ) + 2.0m (34φ)	2.0m (31φ) + 2.0m (34φ)
4.5m (2-piece joint)	2.5m (31φ) + 2.0m (34φ)	2.5m (31φ) + 2.0m (34φ)	2.5m (34φ) + 2.0m (39φ)
5.0m (2-piece joint)	2.5m (31φ) + 2.5m (34φ)	2.5m (31φ) + 2.5m (34φ)	2.5m (34φ) + 2.5m (39φ)
6.0m (2-piece joint)	3.0m (34φ) + 3.0m (39φ)	3.0m (34φ) + 3.0m (34φ)	3.0m (34φ) + 3.0m (39φ)
6.0m (3-piece joint)	2m (34φ) + 2m (39φ) + 2m (39φ)	2m (34φ) + 2m (39φ) + 2m (39φ)	2m (34φ) + 2m (39φ) + 2m (39φ)
Type of joint	 mean insulated joints. Others mean metal joints.		

■ Type of grounding wires (Transparent PVC-sheathed electric wires)

Cross-section area	8mm ²	14mm ²	22mm ²	38mm ²	60mm ²	100mm ²
Element wires	50/0.45	7/38/0.26	7/7/40/0.12	19/38/0.26	19/60/0.26	37/51/0.26
Weight	105g/m	180g/m	265g/m	455g/m	680g/m	1120g/m
Outer diameter	6.6mm	8.4mm	10.1mm	12.9mm	15.2mm	19.0mm

Grounding metal fittings

Grounding fitting (SA107-B,C,D)

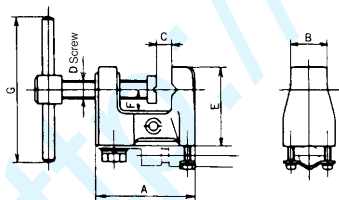

Valve type grounding handle (SA110)

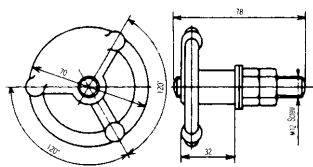

Rail type grounding metal fitting (SA120)

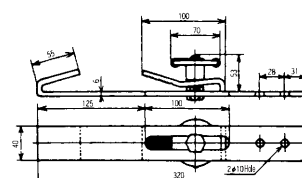
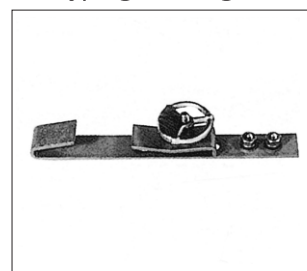

Model	Mounting method	Applicable wire	A	B	C	D	E	F	G	Weight
SA107-B	Screw-in	8mm ² ~ 14mm ²	51	18	18	10	39	13	65	280g
SA107-C	Screw-in	22mm ² ~ 38mm ²	66	24	27	12	53	14	95	570g
SA107-D	Screw-in	60mm ² ~ 100mm ²	90	30	38	12	75	23	95	1080g
SA110	Stud bolt	M12 Stud	Valve type grounding handle							320g
SA120	Stud bolt	38mm ² ~ 60mm ²	Rail type grounding metal fitting							1000g

● Please specify the following items when ordering a grounding hook.

1. Type of the tip metal fitting
2. Type of the insulating rod (Joint and extension type, Telescopic type)
3. Length and diameter of the insulating rod
4. Cross-section area and length of the grounding wire
5. Type of the grounding metal fitting
6. Service voltage

Note

- One set for a three-phase is standard.
- A bag for housing is optional.
- As the product will be custom-made, please note the product may not be returnable to us after once ordered.

Grounding hook parts

■ Table 1 Fixed head metal fittings
(The head metal fitting is fixed on the operating rod.)

Appearance	Model No. & Model name	Serviceable thickness range (mm)	Dimensions	Weight	Remarks
	MA121-A Large type	$\phi 8 \sim 40$		710g	For round bus lines
	MA121-AS Special large type	$\phi 30 \sim 80$		800g	For round bus lines
	MA121-AG Strong and large type	$\phi 20 \sim 52, L=195$ $\phi 40 \sim 80, L=195$ $\phi 70 \sim 150, L=225$ $\phi 100 \sim 180, L=225$		1200g 1920g	For round bus lines (60mm ² or larger grounding wires)
	MA121-C Large and inclined type	$\phi 8 \sim 40$		930g	For round bus lines
	MA111-A Universal type	$\phi 8 \sim 40$ Bus bar thickness : within 12mm Width: within 75mm		930g	For both round and flat bus lines
	MA111-AG Strong and universal type	$\phi 20 \sim 52$ Bus bar thickness : within 20mm Width: within 100mm		1600g	For both round and flat bus lines (60mm ² or larger grounding wires)
	MA111-C Universal and inclined type	$\phi 8 \sim 40$ Bus bar thickness : within 12mm Width: within 75mm		1060g	For both round and flat bus lines
	MA122-A Middle type	$\phi 5 \sim 25$		370g	For round bus lines
	MA114-A Horizontal/inclined copper-belt type	Thickness: within 25mm Width: within 100mm		1000g	For flat bus lines
	MA114-AG Strong and horizontal/inclined copper-belt type	Thickness: within 30mm Width: within 100mm		2250g	For flat bus lines (60mm ² or larger grounding wires)
	MA115-A Cubicle type	$\phi 5 \sim 25$ Bus bar thickness: within 30mm Width: no limitation		500g	For both round and flat bus lines
	MA115-AG Strong cubicle type	$\phi 8 \sim 25$ Bus bar thickness: within 35mm Width: no limitation		1050g	For both round and flat bus lines (60mm ² or larger grounding wires)
	MA115-AN Cubicle type for a narrow space	$\phi 5 \sim 25$ Bus bar thickness: within 30mm Width: within 50mm		480g	For both round and flat bus lines
	MA115-AH Cubicle type with claws	$\phi 5 \sim 25$ Bus bar thickness: within 30mm Width: within 50mm		530g	For both round and flat bus lines

● Please specify the following items when ordering a grounding hook.

1. Type of the tip metal fitting
2. Type of the insulating rod (Joint and extension type, Telescopic type)
3. Length and diameter of the insulating rod
4. Cross-section area and length of the grounding wire
5. Type of the grounding metal fitting
6. Service voltage

Note

- One set for a three-phase is standard.
- A bag for housing is optional.
- As the product will be custom-made, please note the product may not be returnable to us after once ordered.

Table 2 Removable head metal fittings

(The head metal fitting is attachable on and detachable from the operating rod.)

Appearance	Model No. & Model name	Serviceable thickness range (mm)	Dimensions	Weight	Remarks
	MA121-B Large type	$\phi 8 \sim 40$		760g	For round bus lines 5.5mm groove width for ZB model and YB model set
	MA121-BS Special large type	$\phi 30 \sim 80$		860g	For round bus lines
	MA121-BG Strong and large type	$\phi 20 \sim 52, L=200$ $\phi 40 \sim 80, L=200$ $\phi 70 \sim 150, L=200$ $\phi 100 \sim 180, L=230$		1250g 1950g	For round bus lines (60mm ² or larger grounding wires)
	MA121-D Large and inclined type	$\phi 8 \sim 40$		930g	For round bus lines
	MA111-B Universal type	$\phi 8 \sim 40$ Bus bar thickness : within 12mm Width: within 75mm		980g	For both round and flat bus lines
	MA111-BG Strong and universal type	$\phi 20 \sim 52$ Bus bar thickness : within 20mm Width: within 100mm		1680g	For both round and flat bus lines (60mm ² or larger grounding wires)
	MA111-D Universal and inclined type	$\phi 8 \sim 40$ Bus bar thickness : within 12mm Width: within 75mm		930g	For both round and flat bus lines
	MA122-B Middle type	$\phi 5 \sim 25$		420g	For round bus lines
	MA114-B Horizontal/inclined copper-belt type	Thickness: within 25mm Width: within 100mm		1010g	For flat bus lines
	MA115-B Cubicle type	$\phi 5 \sim 25$ Bus bar thickness : within 30mm Width: no limitation		520g	For both round and flat bus lines
	MA105 Operating rod tip metal fitting			170g	Usable for all removable types excluding MA115-B, ZB model and YB model set
	MA105-S Operating rod tip metal fitting			70g	Usable for MA115-B, ZB model and YB model set

● Head metal fittings for grounding hooks used for trolley wires

Appearance	Model No. & Model name	Serviceable thickness range (mm)	Dimensions	Weight	Remarks
	SA106-A Insert type	$\phi 10 \sim 25$		630g	For round bus lines
	SA106-C Insert and inclined type	$\phi 10 \sim 25$		720g	For round bus lines
	SA106-S Small and insert type	$\phi 4 \sim 25$		400g	For round bus lines

● Please specify the following items when ordering a grounding hook.

1. Type of the tip metal fitting
2. Type of the insulating rod (Joint and extension type, Telescopic type)
3. Length and diameter of the insulating rod
4. Cross-section area and length of the grounding wire
5. Type of the grounding metal fitting
6. Service voltage

Note

- One set for a three-phase is standard.
- A bag for housing is optional.
- As the product will be custom-made, please note the product may not be returnable to us after once ordered.

Fixed type

(Set items) = (Operating rod c/w head metal fitting + Grounding wire + Grounding metal fitting)×3

(A bag for housing is optional.)

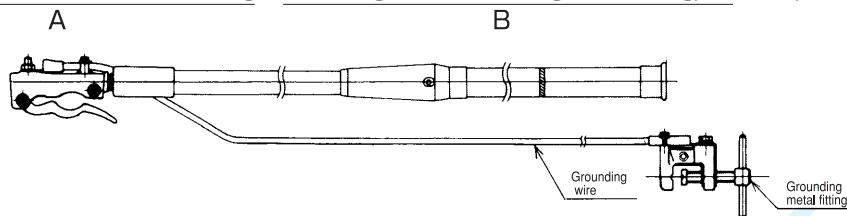

A Head metal fitting type	B Model	Details of the model		Grounding wire	Grounding metal fitting	Applicable voltage	
		Operating rod Length & type					
Large and fixed type MA121-A (MA121-C)	Model 5	NEO pipe	0.5m	One-piece type	22mm ² ×3m	SA107C	6.6kV
	Model 10	//	1.0m	//	//	//	//
	Model 15	//	1.5m	//	22mm ² ×4m	//	22kV
	Model 20	//	2.0m	//	//	//	//
	Model 25	//	2.5m	//	22mm ² ×5m	//	77kV
	Model 30	//	3.0m	//	//	//	//
	Model 35	//	3.5m (1.5+2)	Joint type	22mm ² ×6m	//	//
	Model 40	//	4.0m (2+2)	//	//	//	154kV
	Model 45	//	4.5m (2.5+2)	//	22mm ² ×7m	//	//
	Model 50	//	5.0m (2.5+2.5)	//	//	//	//
	Model 60	//	6.0m (3+3)	//	//	//	275kV
	Model 60	//	6.0m (2×3)	//	//	//	//
Middle and fixed type MA122-A	Model 5	//	0.5m	One-piece type	14mm ² ×3m	SA107B	6.6kV
	Model 10	//	1.0m	//	//	//	//
	Model 15	//	1.5m	//	14mm ² ×4m	//	22kV
	Model 20	//	2.0m	//	//	//	//
Cubicle and fixed type MA115-A	Model 5	//	0.5m	One-piece type	14mm ² ×3m	SA107B	6.6kV
	Model 10	//	1.0m	//	//	//	//

(As for above model 60, please specify 2-joint or 3-joint type.)

Removable type

(Set items) = (Removable head metal fitting + Grounding wire + Grounding metal fitting) ×3 + (Removable type operating rod)×1

(A bag for housing is optional.)

(The max. length is 4 meters for the removable type.)

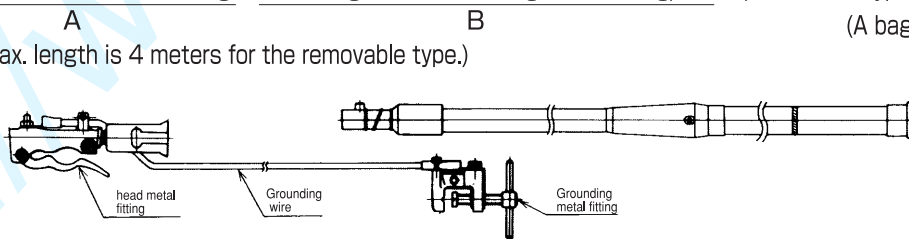

A Head metal fitting type	B Model	Details of the model		Grounding wire	Grounding metal fitting	Applicable voltage		
		Operating rod Length & type						
Large and removable type MA121-B (MA121-D)	Model 5	NEO pipe	0.5m	One-piece type	22mm ² ×3m	SA107C	6.6kV	
	Model 10	//	1.0m	//	//	//	//	
	Model 15	//	1.5m	//	22mm ² ×4m	//	22kV	
	Model 20	//	2.0m	//	//	//	//	
	Model 25	//	2.5m	//	22mm ² ×5m	//	77kV	
	Model 30	//	3.0m	//	//	//	//	
	Model 35	//	3.5m (1.5+2)	Joint type	22mm ² ×6m	//	//	
	Model 40	//	3.5m (2+2)	//	//	//	154kV	
	Universal and removable type MA111-B (MA111-D)	Model 5	//	0.5m	One-piece type	14mm ² ×3m	SA107B	6.6kV
		Model 10	//	1.0m	//	//	//	//
		Model 15	//	1.5m	//	14mm ² ×4m	//	22kV
		Model 20	//	2.0m	//	//	//	//
Model 25		//	2.5m	//	14mm ² ×5m	//	77kV	
Model 30		//	3.0m	//	//	//	//	

■ Operation rod for power transmission lines-compression locking and telescopic type

Model Z

(Set items) = (Operating rod c/w head metal fitting + Grounding wire + Grounding metal fitting) × 3 + (Bag for housing) × 1 or 3

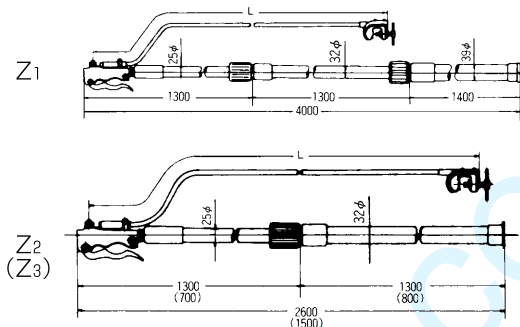
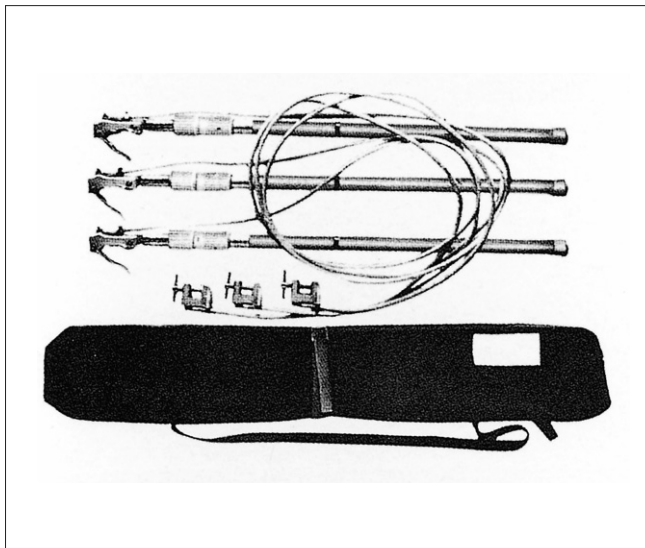

Grounding metal fitting SA107-C Insulating rod (Epoxy resin pipe)

Model	Applicable voltage	Head metal fitting	Grounding wire	Length when extended	Length when shortened	Number of joints	Bag for housing	Weight including the bag weight
Z1	275kV	MA121-A	22mm ² ×5m	4.0m	1.8m	3	Set for 1 phase	15.5kg
Z2	154kV	//	22mm ² ×4m	2.6m	1.5m	2	Set for 3 phase	11.0kg
Z3	77kV	//	22mm ² ×3m	1.5m	1.1m	2	//	8.8kg

■ Operating rod-Push-button and telescopic type

Model Y

(Set items) = (Operating rod c/w head metal fitting + Grounding wire + Grounding metal fitting) × 3 + (Bag for housing) × 1

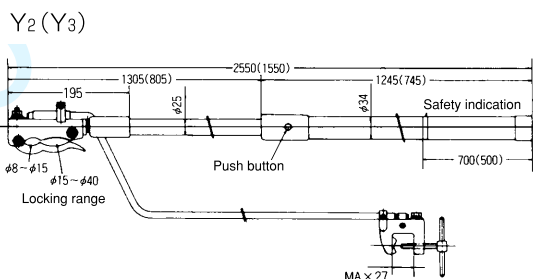
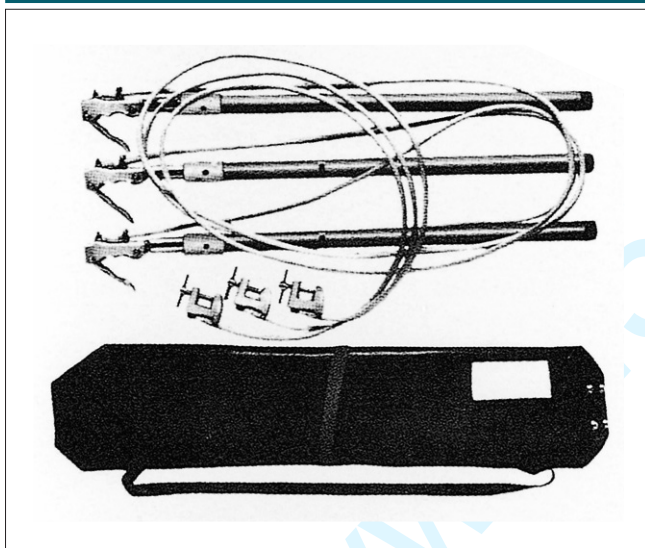

Grounding metal fitting SA107-C Insulating rod (NEO pipe)

Model	Applicable voltage	Head metal fitting	Grounding wire	Length when extended	Length when shortened	Number of joints	Bag for housing	Weight including the bag weight
Y2	154kV	MA121-A	22mm ² ×4m	2.5m	1.4m	2	Set for 3 phase	11.5kg
Y3	77kV	//	22mm ² ×3m	1.5m	0.9m	2	//	9.0kg

Model YB

(Set items) = (Removable head metal fitting + Grounding wire + Grounding metal fitting) × 3 + (Operating rod) × 1 + (Bag for housing) × 1

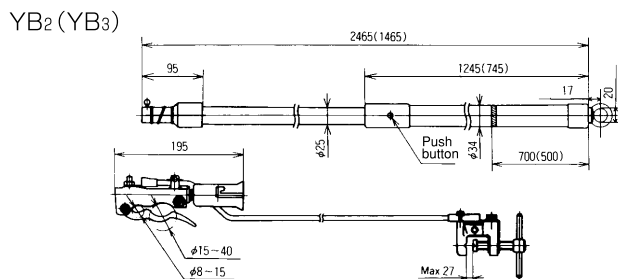
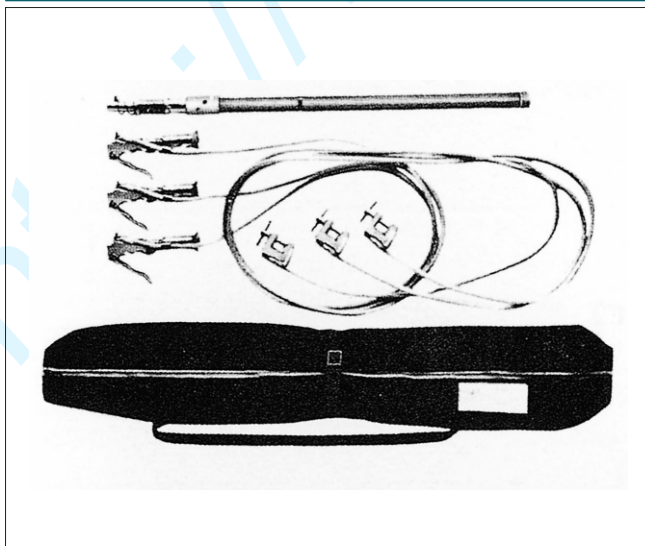

Grounding metal fitting SA107-C Insulating rod (NEO pipe)

Model	Applicable voltage	Head metal fitting	Grounding wire	Length when extended	Length when shortened	Number of joints	Bag for housing	Weight including the bag weight
YB2	154kV	MA121-B	22mm ² ×4m	2.4m	1.4m	2	Set for 3 phase	9.6kg
YB3	77kV	//	22mm ² ×3m	1.4m	0.9m	2	//	8.1kg

Model ZB

(Set items) = (Removable head metal fitting + Grounding wire + Grounding metal fitting) × 3 + (Operating rod) × 1 + (Bag for housing) × 1



ZB2 (ZB3)

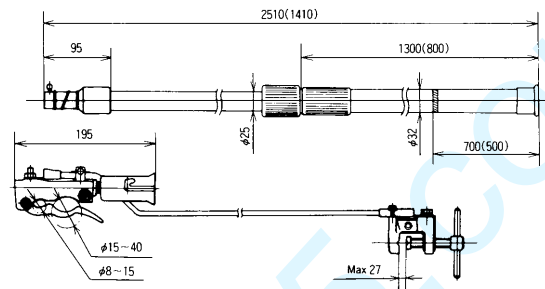

Model	Applicable voltage	Head metal fitting	Insulating rod	Grounding wire	Grounding metal fitting	Length when extended	Length when shortened	Number of joints	Bag for housing	Weight including the bag weight
ZB ₂	154kV	MA121-B (5.5mm groove)	Epoxy pipe	22mm ² ×4m	SA107-C	2.5m	1.5m	2	1550×100 [□] Set for 3 phase	9.3kg
ZB ₃	77kV	MA121-B (5.5mm groove)	Epoxy pipe	22mm ² ×3m	SA107-C	1.4m	1.1m	2	1100×100 [□] Set for 3 phase	7.8kg

■ Discone hook rod (SA109□-□)

Model (SA109)	Indoor	A-1	A-1.5	A-2	A-3	A2-4	A2-5	A2-6	A3-6
	Outdoor		B-1	B-1.5	B-2	B-3	B2-4	B2-5	B2-6
Applicable voltage		10kV	20kV	30kV	40kV	70kV		110kV	
Hook rod length (L)		1.0m	1.5m	2.0m	3.0m	4.0m (2-piece joint)	5.0m (2-piece joint)	6.0m (2-piece joint)	6.0m (3-piece joint)
Rod diameter & Jointing	φ31mm	1.0m	1.5m	2.0m	3.0m	2.0m	2.5m		
	φ34mm					2.0m	2.5m	3.0m	2.0m
	φ39mm							3.0m	2.0+2.0m
Grip length (ℓ _o)		0.3m	0.5m	0.5m	0.7m	0.7m	1.0m	1.0m	1.0m
Tip metal fitting of the discone hook rod		SA108-B			SA108-C		SA108-E		

(Model C)

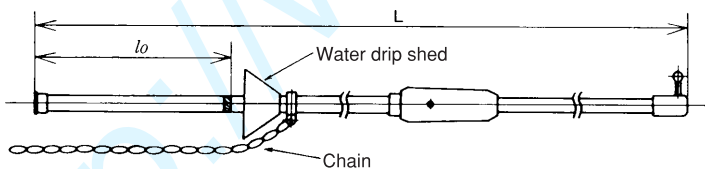

		Chain	Water drip shed
Model A	Indoor	Not provided	Not provided
Model B	//	provided	Not provided
Model C	Outdoor	provided	provided

■ Discone hook rod for cubicles (D□)

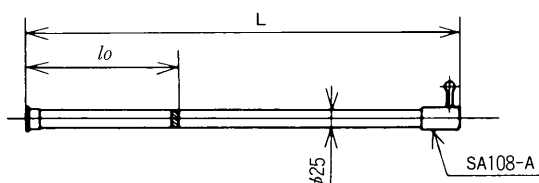

Type	D1	D2	D3	D4
Length (L)	0.5m	1.0m	1.5m	2.0m
Grip length (ℓ _o)	0.3m	0.3m	0.5m	0.5m
Applicable voltage	6.6kV	10kV	20kV	30kV

Grounding hook sets

Best seller series

Model S (for round bus lines) for 6.6~22kV
c/w Carrying case

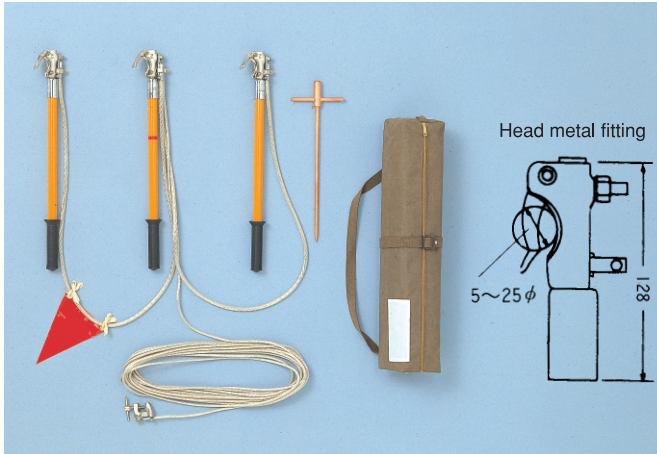

Model F (Universal type for cubicles) for 6.6~22kV
c/w Carrying case

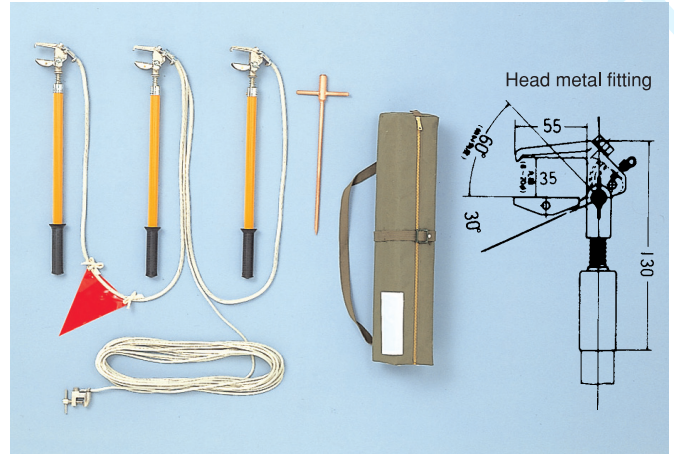

Model C (Universal type for cubicles) for 6.6kV
c/w Carrying case (Narrow space type)

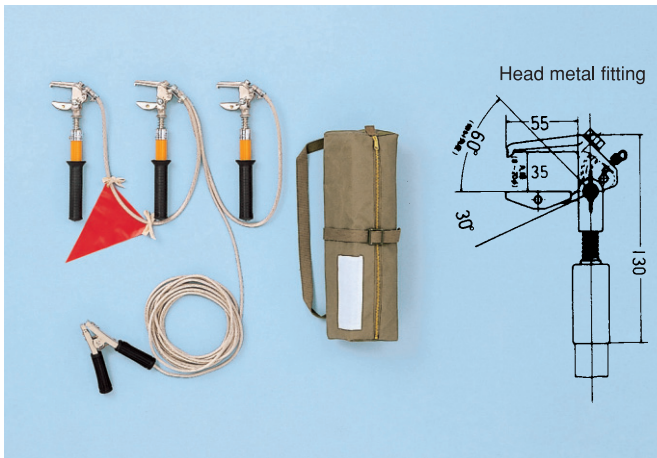

Model H (Universal type for cubicles) for 6.6kV
c/w Carrying case

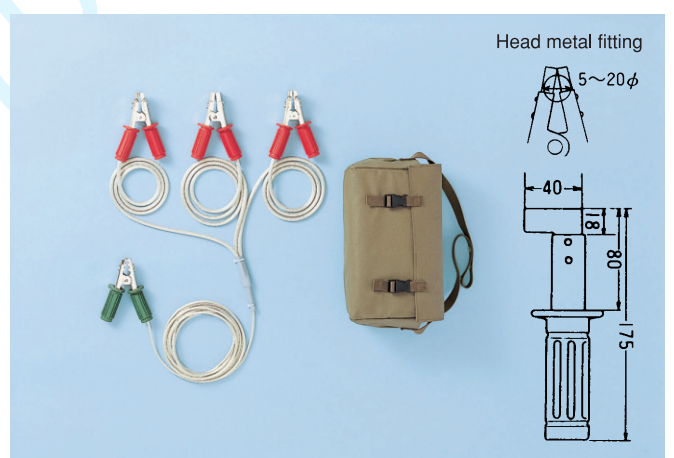

Model	Head metal fitting	Grounding wire	Grounding metal fitting	Grounding rod for driving	Insulating rod length	Bag for housing	Weight
S	MA122-A	22mm ² × 1.5m × 2本 (c/w Triangle-shaped red flag) 8mm ² × 15m × 1本	SA107-B	φ10 Steel rod	NEO Pipe (φ25 × 0.5m) c/w Rubber grip	Portable type 650 × 120 □	5.0kg
F	MA115-AH	22mm ² × 1.5m × 2本 (c/w Triangle-shaped red flag) 8mm ² × 15m × 1本	SA107-B	φ10 Steel rod	NEO Pipe (φ25 × 0.5m) c/w Rubber grip	Portable type 700 × 120 □	5.6kg
C	MA115-AN	14mm ² × 0.7m × 2本 (c/w Triangle-shaped red flag) 8mm ² × 7m × 1本	Clip	Not provided	NEO Pipe (φ25 × 0.2m) c/w Rubber grip	Portable type 450 × 120 □	3.4kg
H	Insulation rubber clip	22mm ² × 1.7m × 3本 8mm ² × 5m × 1本	Clip	Not provided	c/w Rubber grip	Portable type 400 × 120 □	4.0kg

■ Besides above models, we may provide custom-designed ones according to your using conditions.

Model H is manufactured by Hasegawa Electric Co., Ltd.
All other models are manufactured by Sunazaki Seisakusho.

High/Low Voltage Detectors and Instructions for Use

To prevent accidents in electric work, those who are concerned have been always making efforts to do research for improvement of the equipment, work methods, machines and tools, etc. Among those items, the "voltage detector" is essential to prevent electric accidents as it is used to finally check live or dead conditions of the electric lines and equipment at the work site.

It is often the case with electric work that electric-shock accidents occur because live lines are misidentified as dead lines. Before touching electric wires, workers must use a voltage detector to check that the line is dead. This is designated as a duty in the Ordinance on Labor Safety and Hygiene (Article 339).

The voltage detector is a device to determine if the electric line is live or dead. A wide variety of voltage detectors have been produced and used until today, but there was no official standard on the structure and performance of voltage detectors. Many of those detectors were manufactured according to the in-house specifications of users such as electric power companies etc. In recent years, however, battery-built-in and electronic-circuit type voltage detectors have been developed. As the result of it, respective manufacturers began to produce many types of voltage detectors which have complicated structures and a variety of operational characteristics. To deal with this, the industrial safety research institute of the Ministry of Labor has recently announced the guidelines for the structure, performance, test methods and use of those types of voltage detectors so as to make it widely known to the public how to select and use those voltage detectors.

The following are explanations on the structure, performance and correct using methods of high and low voltage detectors widely used in public.

Voltage detector's structure and operating principle

In general, voltage detectors are structured with a detecting part incorporated in an insulating enclosure. As shown in Figure 1, when the tip of the detecting part contacts an electric line, the detector identifies a slight electric current I_0 flowing through the route of the electric line → detecting part → stray capacitance to ground in the detecting part C_0 → Earth. As the result of it, the detector shows if the electric line is live or dead by means of representation of light and sound.

Voltage detectors may be classified into a variety of types depending on the service voltage such as the low voltage, high voltage, special high voltage, etc. and also depending on the applications such as the overhead lines, electric power substation, etc. For example, there is a screwdriver-shaped one for low voltage which is used for checking electric conditions of plug sockets or cord terminals at ordinary households. There are also many types including a pencil-shaped voltage detector which are used for construction or maintenance work of the electric power supply systems.

Since before, neon-glow lamp type voltage detectors have been widely used as they offered advantages in that they are made in a simple structure requiring no power supply. However, this type gives out a less brilliant light, so there was a difficulty in recognizing lighting up of the unit in the case of voltage detection made directly on the live part. In addition, insulated wires have come to be used for high voltage lines these days. Thus, it became difficult to recognize the dead lines using neon-glow lamp type voltage detectors. It meant that users desired to have another type of voltage detector which is more excellent than neon-glow type voltage detectors. After experiencing such circumstances, voltage detector manufacturers have developed new type of voltage detectors which incorporate a battery and an amplifying circuit and enable voltage detection and representation even over insulated wires. Those new types are commercially available today.

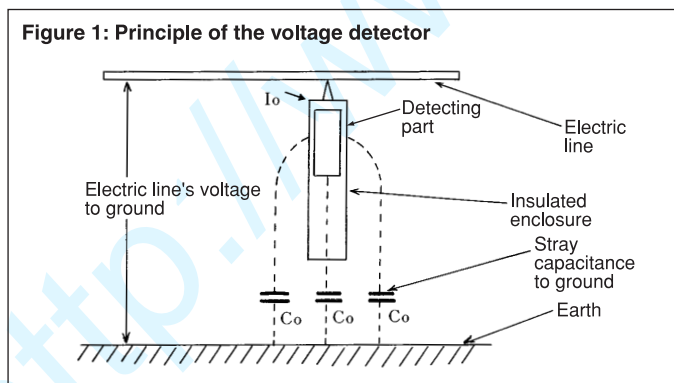

(1) Neon-glow type voltage detector (Figure 2)

When a neon glow lamp receives application of a voltage higher than its discharge voltage, it makes a glow discharge with a brilliant orange light even if the applied voltage is slight. Neon-glow type voltage detectors are made based on this principle. They are made of a very simple structure and easy-to-handle, so widely used since before as voltage detectors for low, high and special high voltage. Their disadvantages are it is difficult to recognize their light emission in a bright place and that voltage detection is impossible on the coating of insulated wires.

Figure 2: Neon-glow type voltage detector

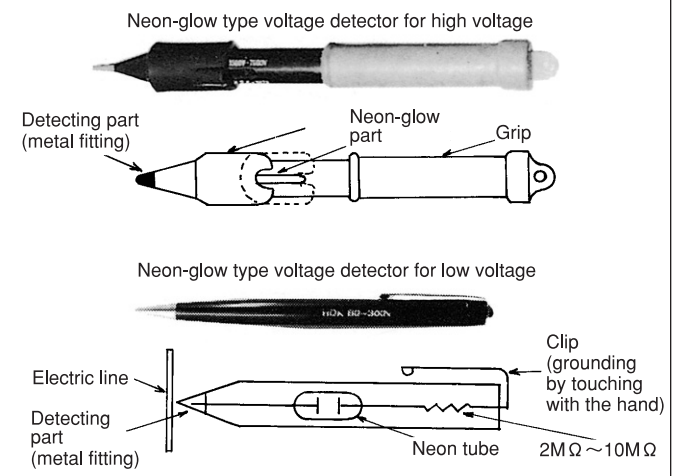

(2) Electronic-circuit type voltage detector (Figure 3) (Figure 4)

This type of voltage detector incorporates a battery and an electronic amplifying circuit made of semiconductors. A slight electric current detected will be amplified in the incorporated circuit, which makes an indication lamp light up clearly. On the other hand, its switch circuit and oscillation circuit will convert such slight electric current to an audio frequency, which generates a clear sound. In those ways, this type of detector may determine if an electric line is live or dead.

Thanks to the design of an amplifying circuit, it is possible produce voltage detectors having a variety of characteristics. The big advantages of this model are it can be used for both high and low voltage detection and that it is possible to detect voltage on the coating of insulated wires. In addition, the electronic-circuit types are provided with a button to easily check conditions of the battery and incorporated circuit, making it easier to check functions of voltage detectors.

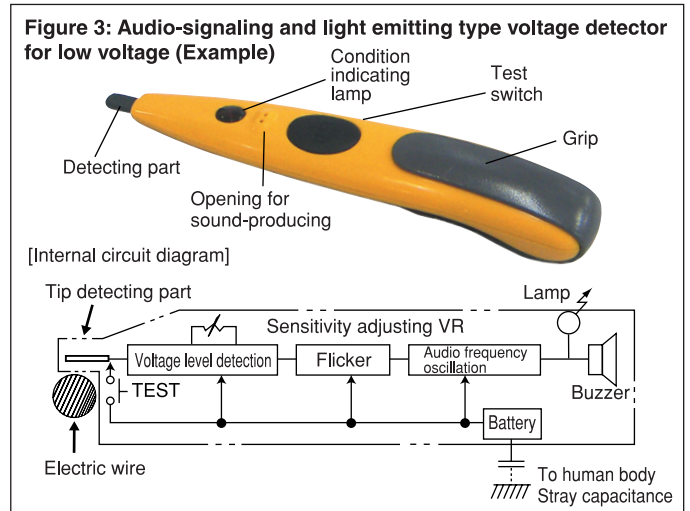

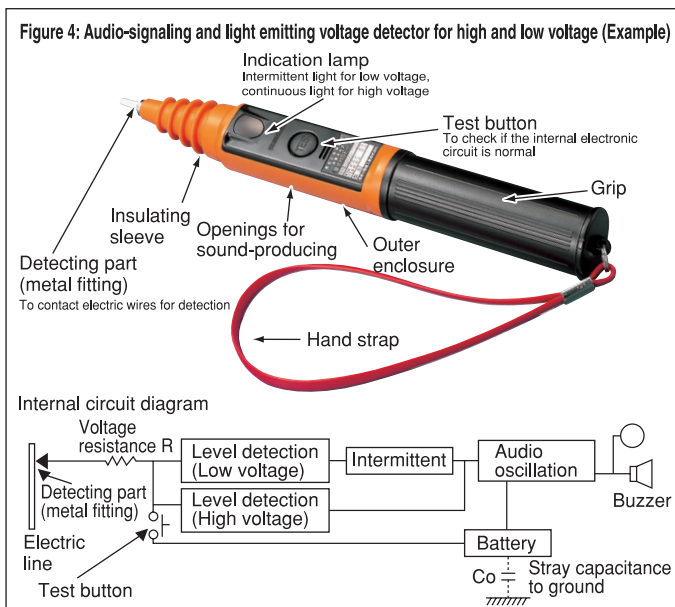

Performance required for voltage detectors

In view of the using purpose, the voltage detecting sensitivity (operation starting voltage) should be most important among the main features of voltage detectors. It may be considered that the higher sensitivity means the higher performance, but as a matter of actual usage, there is a fear that the higher sensitivity may cause many more unnecessary indications and operations. In addition, it is important to consider the safety of users related to the dielectric strength as well as the indication methods related to the accuracy of detection.

● Operation starting voltage (The lowest detectable voltage)

In general, voltage detectors are used to check the voltage (to ground) of an electric line conductor; where an operator make the top detecting part contact one of the wires in the electric line while holding the detector itself or the end of the insulated rod. In this respect, the voltage to ground is indicated as the operation starting voltage.

As shown in **Figure 5**, the voltage of high and low voltage circuits to be checked by a voltage detector means the voltage to ground which is lower than the line-to-line voltage. If an electric line (wire) is grounded, its voltage to ground is zero; which means voltage detection is impossible as a matter of course.

(1) **Low voltage detectors** are generally made for detecting 100V (95 ~107V) of the minimum circuit voltage. Therefore, it is designated that the operation starting voltage should be set at $65V \pm 15V$ or at less than 80V. In the case of low-voltage specialized detectors, some of them are set at less than 50V (50V means the voltage to ground which is lowest permissible level restricted by the Ordinance on Labor Safety and Hygiene) because there is no need to consider an effect of induction by high voltage.

(2) **As for high voltage detectors**, the operation starting voltage of some units is set at 300V. It is because 300V or higher voltage is regarded as the high voltage based on the standard that 254V is the voltage to ground for the 440V three-phase four-wire line which is the maximum voltage as the low voltage circuit. On the other hand, the operation starting voltage of some other units is set to detect 600V and higher voltage. This is according to "The AC high voltage means the range between 600V and 7,000V" as designated in the technical standard on electric equipment (ministerial ordinance).

Table 1: Examples of voltage detector standards

	Operation starting voltage (V)		Remarks
	Bare wire (a)	Covered wire (b)	
Company A	250±50	(Less than 2900)	Audio-signaling and light emitting type
Company B	300±50	(Less than 3300)	〃
Company C	Less than 1000	Less than 3300	〃
Company D	1000±200	2800±500	〃

Note:
 (1) The ratios between the figures in (a) and (B) are widely different between the companies A, B and C, D because of the structures of respective voltage detectors are different with each other.
 (2) Figures in the parentheses of the column (b) are not indicated as the standard of the voltage detectors, but they are the standard for practical use.
 (3) The company A's detector may be used for both 50/60Hz, but the others are for special use for a specified frequency.
 (4) The above table describes only on the high voltage range of high voltage detectors. (The low voltage range is $65 \pm 15V$ for all the companies.)

There are also some other types of high voltage detectors used, in which the operation starting voltage is set at different levels depending on the electric line conditions and the applications. For example, in order to avoid malfunctions caused by inductions from a live line, the operation starting voltage is set at 1,000V (about one-half plus an allowance) of 1,900V which is the voltage to ground in a 3,300V circuit. In some other cases, the operation starting voltage is set at 3,300V (including an allowance) so as to detect the voltage to ground of 3,800V on a coated wire in a 6,600V circuit. As a rule in view of the safety of voltage detection work, it is appropriate to set the operation starting voltage value so as to check the voltage to ground on the coated wire of the circuit.

Table 1 shows some examples of the standards of voltage detectors used by electric power companies in Japan.

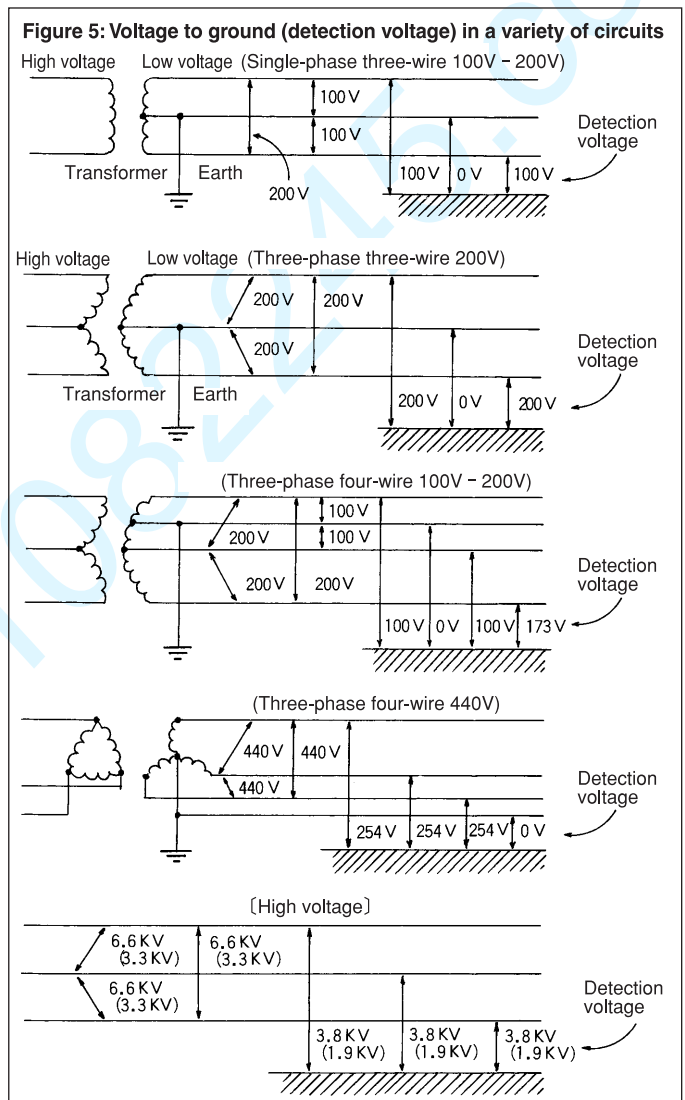

● Non-operating distance

As a voltage detector approaches a high voltage circuit, the detector will start operation when it comes at a certain distance from the circuit. If the detector starts operation in a position which is too far away from the circuit, it is often the case with detection work that live lines and dead lines can not be distinguished. Such a situation is not only useless but also dangerous. To solve this problem, voltage detectors are provided with a minimum distance setting for non-operation (called a non-operating distance). In general, high voltage detectors are provided with 3-5 cm non-operating distance setting.

● Dielectric strength

In view of the actual using conditions, high voltage detectors in particular must meet the standard for faulty insulator detectors etc. as the devices for live line work stipulated in Article 9 of Notice No. 33 of the Ministry of Labor. As a rule, voltage detectors must be proof for one minute against application of an AC test voltage which is two times higher than the voltage in the electric line for detection. Some battery-incorporated type voltage detectors are provided with a dielectric strength of 14,000V (6,900V×2), and also some others have the dielectric strength of 20,000V.

● Representation of the result of detection (Light & Sound)

The result of voltage check by voltage detectors must be shown by giving out either light or sound (as specified in the voltage detector safety guidelines).

As a rule in the case of representation by light emission, voltage detectors are provided as to make it possible to recognize the light emission in the brightness of 8,000 lx which is almost same brightness in the shade under a clear sky (out of the sun).

In the case of representation by sound, it may be sometimes necessary to consider, as one of using conditions of voltage detectors, a loud noise of 80 dB in a place such as the vicinity of downtown streets. In normal cases, however, most of the noise may be included in the low frequency range. Therefore, it is sufficient to give out sound of 50 db or louder generating the sound of about 3,000 Hz which can be recognized by people most easily.

How to use voltage detectors correctly

● Reliable inspection before use

As voltage detectors are essential to guard workers' lives, they must be always kept in storage and handled carefully. Please always check the appearance and lighting up conditions before use. Any faulty ones must be immediately replaced.

- ① Check that the service voltage range of the detector meets the voltage range of the electric line.
- ② Visually check if any damage, dirt, scars, cracks of the detector.
- ③ Check that the detector operates normally using a verified power source, a voltage detector checker (Figure 6), etc.
- ④ A battery incorporated type voltage detector should be checked that its battery voltage in the internal circuit is normal by means of the check mechanism (test button).

Figure 6: Voltage detector checker



■ Do not use a low voltage detector for high voltage detection

If a voltage detector provided with a high sensitivity, such as a low voltage detector, is used for high voltage detection, the following problems will be caused.

The electric field distribution generated in the space around a live electric line differs greatly depending on the locations of electric wires and the conditions of grounded objects around the electric line. The size of the electric field generated depending on the distance from the electric wires may not be always constant, and there is a danger that the size may become larger enough to generate a high voltage which exceeds a safety limit of the dielectric strength of the low voltage detector. In addition, if there is another live electric line is located near the dead electric line for voltage detection, the detector may operate in response to the live line, thus showing a status as if the deal line is live. Therefore, low voltage detectors should not be used for high voltage detection. They may be used as a simple auxiliary warning device, though.

● Precautions before voltage detection

- ① Before performing voltage detection, carefully check the condition of the electric line in view of the condition of circuit breakers, indication lamps, circuit diagrams, etc.
- ② Depending on the type of the voltage detector, prepare using conditions by extending and tightening up the insulated rod.
- ③ During detection work, avoid touching any dangerous parts other than the grip of the detector.
- ④ For high voltage detection, wear insulated rubber gloves if the hands will be located in a place 60 cm or less away from the high voltage parts. If you use a voltage detector with a normal length of about 25

cm, always wear insulated rubber gloves. If you don't wear any protective goods in a case such as a periodical maintenance, you must use a longer voltage detector provided with an insulating rod.

- ⑤ Stop using voltage detectors if there is a danger of surge voltage generated in the case such as a lighting, operation of breakers and switches, etc.
- ⑥ As a rule, avoid performing voltage detection work in the rain. If you have no choice but to do so, check that the voltage detector has a reliable structure for operation in the rain, and be careful with wetting of the detector to recheck if there is no danger of an electric shock.
- ⑦ Perform voltage detection individually for each one of all the phases.
- ⑧ The voltage detector should be brought from the earth side to the electric line for detection.
- ⑨ High voltage cables can not be inspected because their conductors are grounded after shielded with conductive tapes. (Figure 8)

Voltage detection work of high voltage cables are performed using a special type voltage detector at the terminal for detection which is installed at the cable terminals. Sometimes an electric current detector is used for detection of the electric current flowing in the cables.

Figure 7: How to contact the detecting part to the surface of coated wires

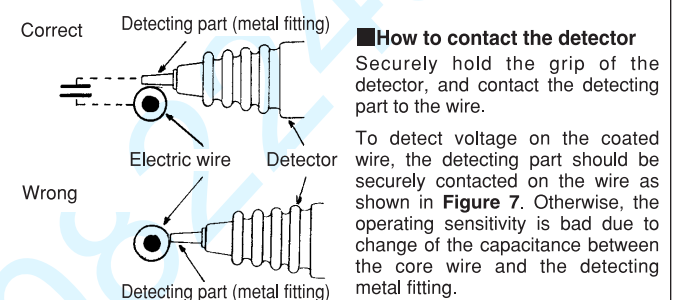
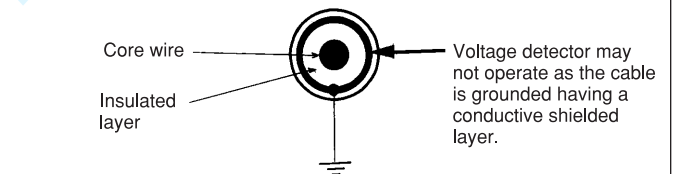

Figure 8: High voltage cables can not be inspected.



● Directions for carrying and storage

- ① Treat your voltage detector with care and avoid any strong impact or pressure due to dropping, crushing, etc.
- ② Do not leave the detector on the road in summer or in a heated-up place such as the inside of a car.
- ③ It may cause condensation on the detector to suddenly bring it out of a warm room to the cold outdoor. Be careful not to cause condensation. Otherwise, the unit may be damaged.
- ④ For storage of the detector, please select a dry and clean indoor place where no sunlight is admitted.

● Periodical inspections are necessary.

Voltage detectors are not subject to the regulation for periodical voluntary inspections stipulated by law (Ordinance on Labor Safety and Hygiene). Different from work tools such as pliers, screwdrivers, etc., however, voltage detectors are important safety devices to protect workers against electric shock accidents in electric work sites. Therefore, it is deemed desirable to conduct periodical inspections on the dielectric strength performance of detectors. (Voltage detector safety guideline)

- ① As for high voltage detectors, dielectric strength tests should be performed at least once a year. The test must be carried out for one minute under the condition of the test voltage of 10kV or higher.
- ② Batteries incorporated in voltage detectors may be dead due to natural discharge even if they were not used. Check them at the time of periodical inspections, and replace them if they are dead.

Influence due to special using conditions

The environment where a voltage detector is used varies from place to place, so it is often the case with a voltage detector that the detecting performance differs depending on the using conditions. The following are particularly influential examples:

(1) If the grip is not held correctly:

If you use a general type of portable short-length voltage detector taking its one end only with your fingers instead of securely holding its grip, the operation starting voltage will be larger than usual because the capacitance value C_1 will be smaller than usual as shown in the equivalent circuit of **Figure 9**.

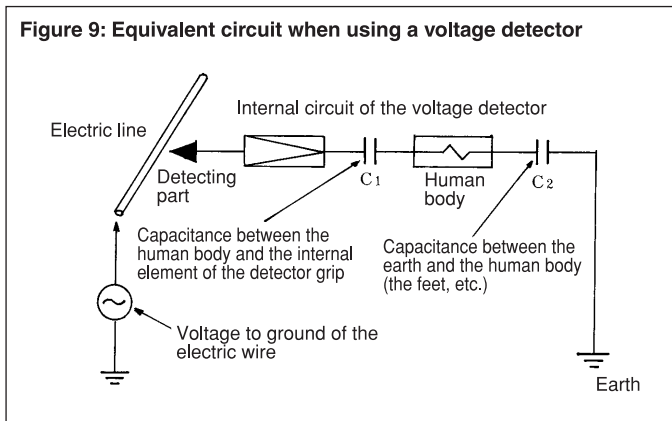

(2) If performing voltage detection near a high voltage electric line:

On an electric power pole or in an electric room, if you make the detecting part of a high or low voltage detector (including an incorporated battery) contact a grounded wire or a grounded metal, it is often the case with the voltage detector to indicate "a voltage is detected".

This is because, as shown in **Figure 10**, an induced current flows backward from the detector grip to the detecting part after a voltage to ground is generated in the human body or the detector grip located near the high voltage electric line due to induction from live wires. To deal with a case like this, please go away from the high voltage electric line or bring the detector from the earth side. Doing so will reduce induction and may avoid abnormal conditions.

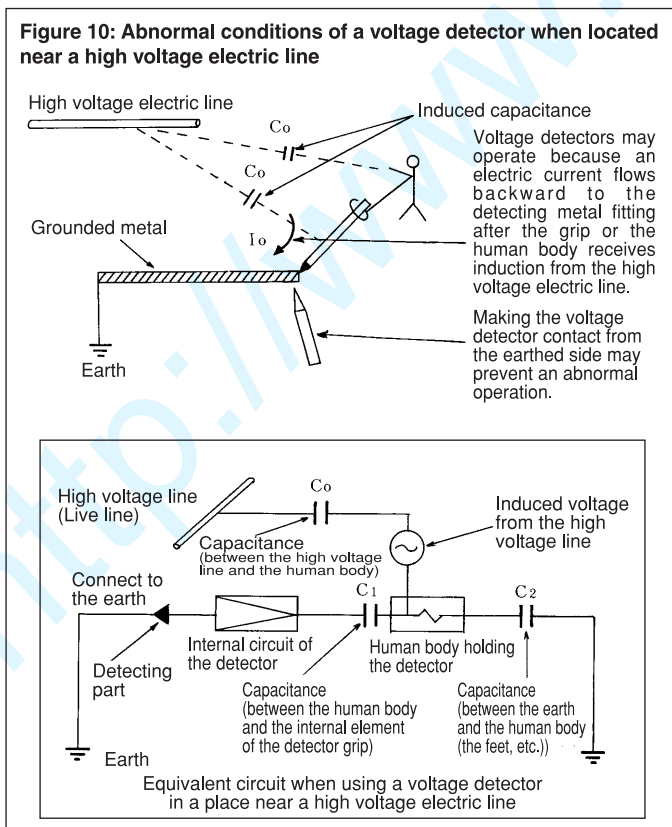

(3) If using a voltage detector for an ungrounded machine

Voltage detectors are made with an extremely large impedance set between the detecting part and the human body in order to extremely reduce a current flow into the human body for safety. Because of this, as shown in **Figure 11**, if the machine's enclosure is not grounded, voltage detectors may operate when the machine's induction capacitance is large enough; even if the machine is normally insulated.

In such a case, it is necessary to check that the machine is perfectly grounded. On the other hand, if the machine is a low voltage type and installed without grounding, it is safe to check that the machine's voltage is not dangerous using a meter with rather low impedance like a "tester".

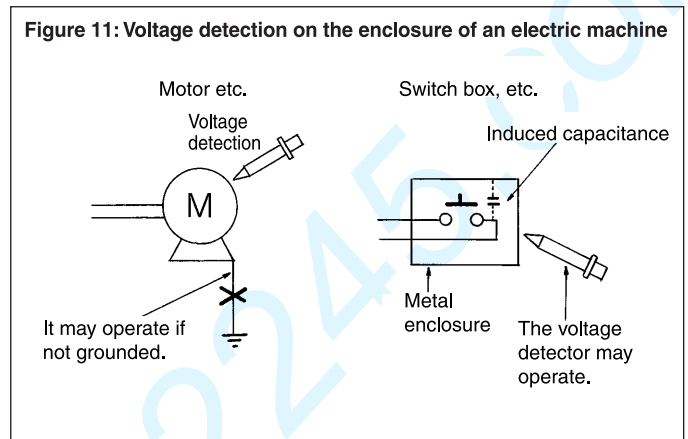

As above, we gave a summary of explanation on high and low voltage detectors. Needless to say here again, voltage detectors are important to ensure safety of workers during electric work, so it is desired to use them correctly after understanding the mechanism of voltage detectors. We hope this instruction manual will help you.

As for the details of regulations etc. cited herein, please refer to the following:

- Article 339 of Ordinance on Labor Safety and Hygiene (Working during power outage)
- Article 342 of Ordinance on Labor Safety and Hygiene (Working near high voltage lines)
- Article 348 of Ordinance on Labor Safety and Hygiene (Insulated protective tools etc.)
- Article 352 of Ordinance on Labor Safety and Hygiene (Inspection before use etc.)
- Article 354 of Ordinance on Labor Safety and Hygiene (Exclusion from applications)
- Amendment of No. 33 Notice from the Ministry of Labor in 1975 (Standards of Insulated protective tools etc.)
- Technical guideline of the Industrial Safety Research Institute of the Ministry of Labor
RIIS ~ TR ~ 85 ~ 2
(Safety guideline for portable voltage detectors for high voltage electric lines)

服务全心全意 品质精益求精

上海山合海融商贸有限公司

<http://www.shhairong.cn>

<http://www.51082245.cn>

<http://www.51082245.com>

E-mail : sh@51082245.com

电话 : 021-51082245

传真 : 021-56889347

QQ : 1742312421

MSN : shhairong@hotmail.com

贸易通 : lzzsbj